







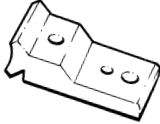

Workbench or Table

SECTION 1

You should have :

ITEM	QTY	ITEM	QTY
 Trim	8	 Grub Screw	48
 Leg	4	 Joining Bracket	16
 Long Beam	4	 Screw	6
 Short Beam	4	 Work Top Clip	6
TOOLS		 Leg-End Cap	4
 Allen Key	1		
 Spacer	1		

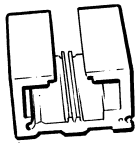
- Put a **grub screw** backwards into each of the **joining brackets** - do not place **grub screws** in the other holes at this stage.

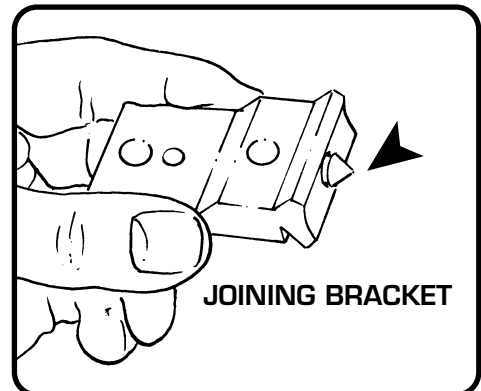
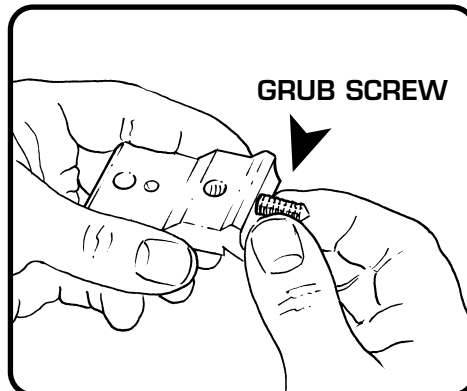
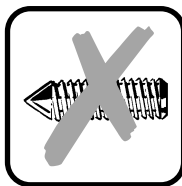
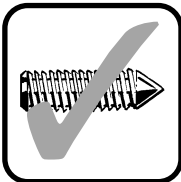

- Attach the **joining brackets** to the **legs**.

At this stage you need to decide the format of your bench/table. Here are a few ideas :

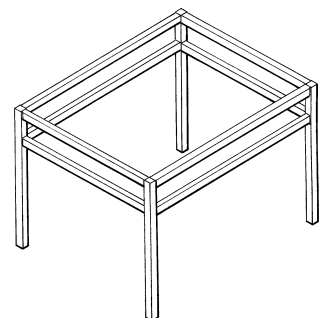
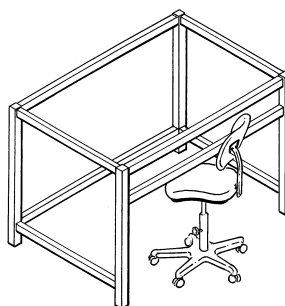
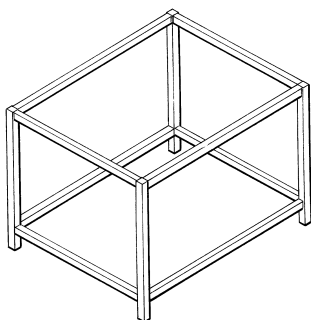









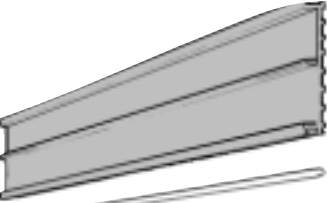

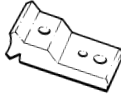
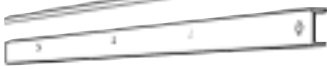

Single Matboard Storage Unit

SECTION 3

NOTE: If you are assembling an extension unit *with* a standard unit – go to section 5

You should have :

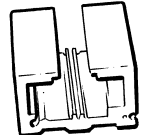
ITEM	PD02	PD07	ITEM	PD02	PD07
 Base Channel	10	7	 Grub Screw	42	42
 Dividing Rod	33	24	 Joining Bracket	14	14
 Fixing Channel	2	2	 Screw	6	6
 Dividing Rod Support	3	3	 Work Top Clip	6	6
 Trim	8	8	 Leg-End Cap	4	4
 Leg	4	4	 Cap screw	6	6
 Beam	3+4	3+4	 Washer	6	6
TOOLS					
 Allen Key		1			
 Spacer		1			

1 Put a **grub screw** backwards into each of the **joining brackets** - do not place **grub screws** in the other holes at this stage.

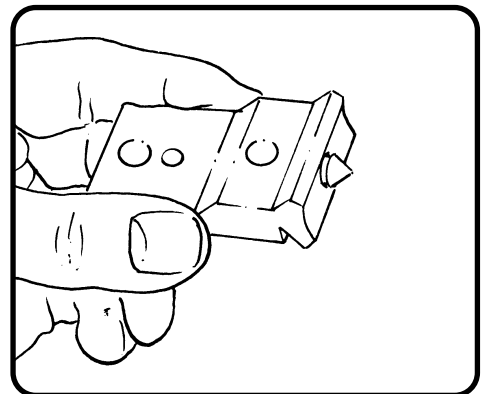
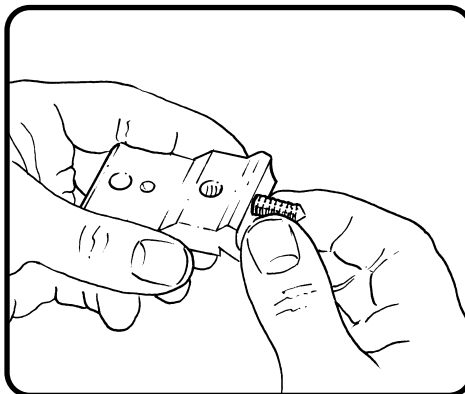
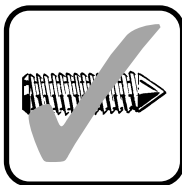

Adding a Matboard Storage Unit Extension

SECTION 4

NOTE: If you are assembling an Matboard Storage unit **with** an extension unit – go to section 5

You should have :

		PR02	PR07			PR02	PR07
	ITEM			ITEM			
	Base Channel	10	7	Grub Screw	30	30	
	Dividing Rod	33	24	Joining Bracket	10	10	
	Beam with holes	1	1	Screw	4	4	
	Dividing Rod Support	3	3	Work Top Clip	4	4	
	Trim	2	2	Leg-End Cap	2	2	
	Leg	4	4	long Cap screw	3	3	
	Beam	3+4	3+4	Nut	3	3	
			Washer	6	6		
TOOLS		ITEM	QTY				
		Allen Key	1				
		Spacer	1				



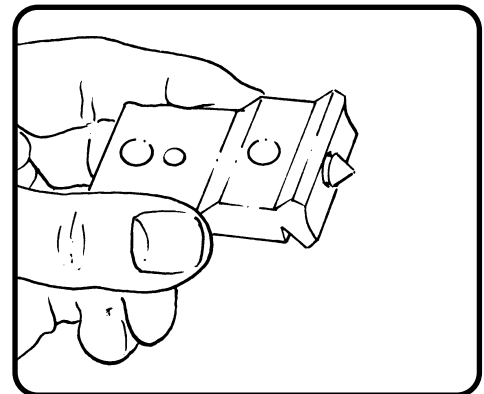
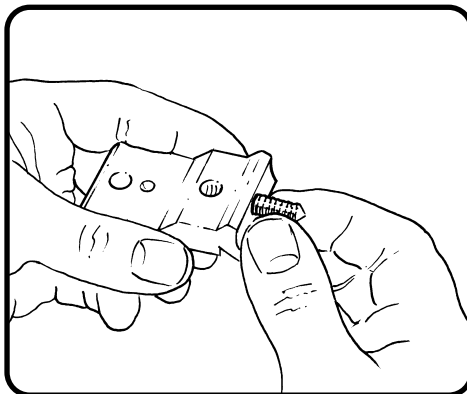
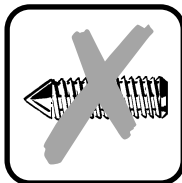
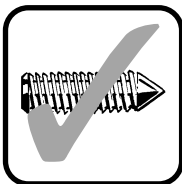

1 Put a **grub screw** backwards into each of the **joining brackets** - do not place **grub screws** in the other holes at this stage.

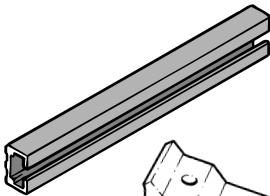

Fitting Cantilever Matcutter Supports

SECTION 9

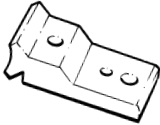
You should have :

ITEM	QTY	ITEM	QTY
	2		6
	2		2
			2

TOOLS		ITEM	QTY
		Allen Key	1

- Put a **grub screw** backwards into each of the **joining brackets** - do not place **grub screws** in the other holes at this stage.

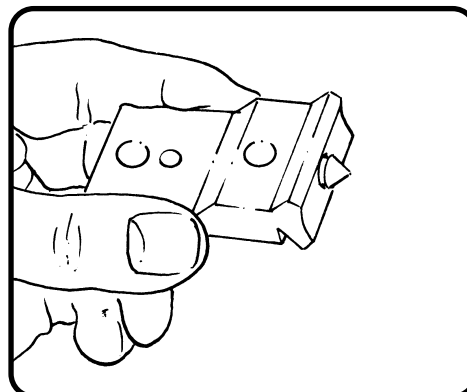
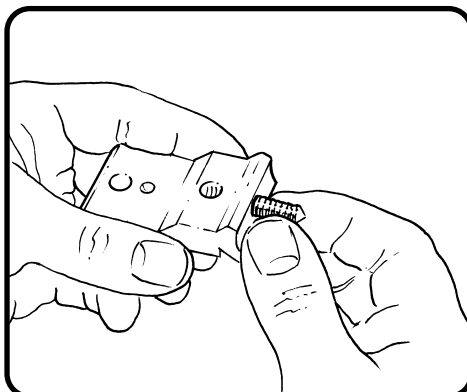
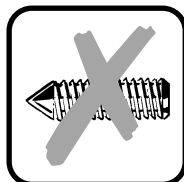
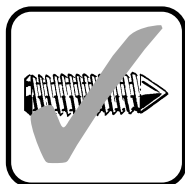

- Attach the **joining brackets** to the **legs**

Decide upon the height required for the **supports** and fit the **brackets** on two adjacent **legs** accordingly.

Note: the flat faces of the bracket should face each other.

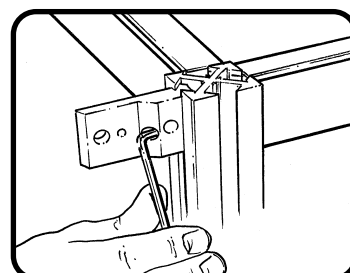
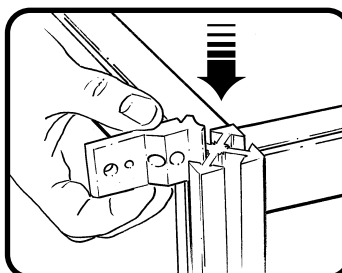

- Attach the **beams** to the **brackets**

Assemble the two **beams** on to the **brackets** and fasten with the grub screws.

Fit the **beam end caps**.

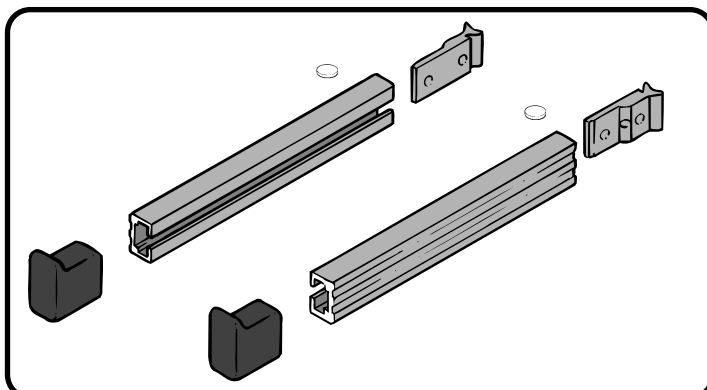

- Placing a matcutter

When placing a matcutter directly on to the **supports** (ie. when not extending the worktop across them) place the **rubber pads** on the **beams** to support the right hand edge of the cutter.